



**Allgemeine Sicherheitshinweise**  
**General safety notes**



\* Montage / Wartung nur durch Fachkräfte.  
\* Bei Instandsetzung / Instandhaltung nur Originalteile verwenden.

\* Werden nachträglich Änderungen an Leuchten vorgenommen, so gilt derjenige als Hersteller, der diese Änderung vornimmt.

\* Der Hersteller übernimmt keine Haftung für Schäden, die durch unsachgemäßen Einsatz entstehen.



\* Installation / maintenance only by skilled personnel.  
\* During overhaul / maintenance only use original parts.

\* If any luminaire is subsequently modified, the person responsible for the modification shall be considered the manufacturer.

\* The manufacturer bears no liability for damage caused by inappropriate use or application.

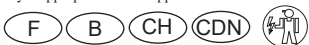

\* Les opérations d'installation et d'entretien doivent être effectuées exclusivement par des personnes qualifiées.

\* Dans le cas d'une remise en état, utiliser uniquement des composants d'origine.

\* Toutes modifications apportées au luminaire se feront sous la responsabilité exclusive de celui qui les effectue.

\* Le fabricant décline toute responsabilité résultant d'un mise en oeuvre inappropriée du produit.



\* El montaje y mantenimiento lo efectuarán únicamente los técnicos especializados.

\* Para reparaciones han de emplearse solo piezas originales de recambio.

\* Reservado el derecho de modificación de dimensiones, pesos y características técnicas, sin previo aviso.

\* El fabricante no asume responsabilidad por modificaciones realizadas por terceros, ni por instalación incorrecta.



\* Montaggio / Manutenzione solo per mezzo di Personale specializzato.

\* Per Riparazione / Manutenzione impiegare solo Parti originali.

\* Il costruttore si riserva il diritto di apportare senza preavviso modifiche di peso, dimensioni e caratteristiche tecniche.

\* Il costruttore non è responsabile per danni derivanti da modifiche realizzate da terzi e da una installazione non corretta.



\* Montagem/Manutenção efectuada unicamente por pessoal técnico especializado.

\* Utilizar somente peças originais do fabricante.

\* O fabricante não se responsabiliza por danos resultantes da inadequada utilização dos materiais.



\* A szerelés / karbantartást csak szakszemélyzet végezheti

\* Üzembehelyezéssel / karbantartással csak eredeti alkatrészek használhatók.



\* Τοποθέτηση / Συντήρηση μόνο από ηλεκτρολόγο

\* Κατά την επισκευή / διατήρηση χρησιμοποιείτε γνήσια ανταλλακτικά μόνο



\* Montage / service alleen door vakkundig personeel.

\* Bij inbedrijfstellen / onderhoud alleen originele onderdelen gebruiken.



\* Monteres kun av fagpersonell.

\* Ved feilretting : Bruk kun originaldeler.



\* Montering akötsel endaa av fackfolk.

\* Använd bara originaldelar vid igångsättning / underhall.



\* при ремонте применять только те же самые части.

\* Монтаж / обслуживание только специалистами.



\* Montá a údr ba ml e být prováděna výhradně odbornou pracovní silou.

\* Při údr bž nebo opravě musí být pou ity jen originální náradní díly.



\* Montaj ve Bakim sadece yetkili personel tarafindan yapilmalidir.

\* Bakimda sadece orjinal parcalar kullanimalidir.



\* Montaż / konserwacja tylko przez fachowy personal.

\* Dla naprawy / bieżacej eksploatacji stosować tylko oryginalne części zamiennie.



\* Monta o/vzdr evanje lahko izvrši le ustrezno usposobljena oseba.

\* Pri popravilu/vzdr evalnih delih se lahko uporabljajo samo originalni deli.

\* V kolikor se na svetilkah naknadno izvedejo spremembe, se za proizvajalca svetilke smatra tisti, ki je izvedel spremembo.

\* Proizvajalec ne jamči i za škodo, ki bi nastala zaradi nepravilne uporabe.



\* Monta u/odr avanje mora vršiti odgovarajuće osposobljena osoba.

\* Pri popravku/odr avanju koristiti samo originalne dijelove.

\* Ukoliko se na svjetiljkama naknadno vrše promjene, za proizvođača

svjetiljke se smatra taj koji je promjene izvršio.

\* Proizvođač ne garantuje za štetu koja bi mogla nastati usled nepravilne upotrebe.



\* Monta u/odr avanje mo e da obavi samo stručno osposobljena osoba.

\* Pri popravljanju/odr avanju upotrebljavati samo originalne delove.

\* Ukoliko se na svetilkama naknadno urade izmene, za proizvođača svetilke će se smatrati onaj ko izmene izvrši.

\* Proizvađač ne garantuje za štetu koja bi mogla nastati usled nepravilne upotrebe.

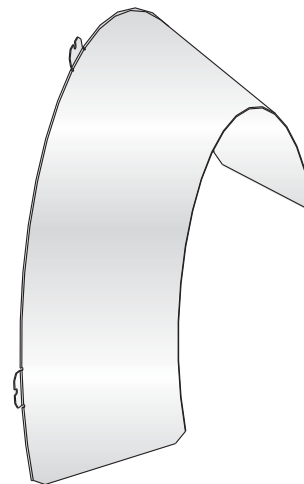

# siteco

Siteco GmbH  
Georg-Simon-Ohm-Straße 50  
83301 Traunreut, Germany  
mail: technicalsupport@siteco.de  
Phone: +49 8669 / 33-844  
[www.siteco.com](http://www.siteco.com)

Montage- /  
Betriebsanleitung  
Mounting- /  
Operating instruction

## Fluter floodlight



### SiCOMPACT ® R3 MAXI

### Hagelschild hail shield

### 5NA75600XH

Bestellnr./Order-number: 5MA75-241971  
copyright Siteco  
Änderungen vorbehalten  
ab / PIE / 20.08.2012

Bitte aufbewahren!  
Please keep for future reference!

1 [ mm ]  =0,6 kg  T20 

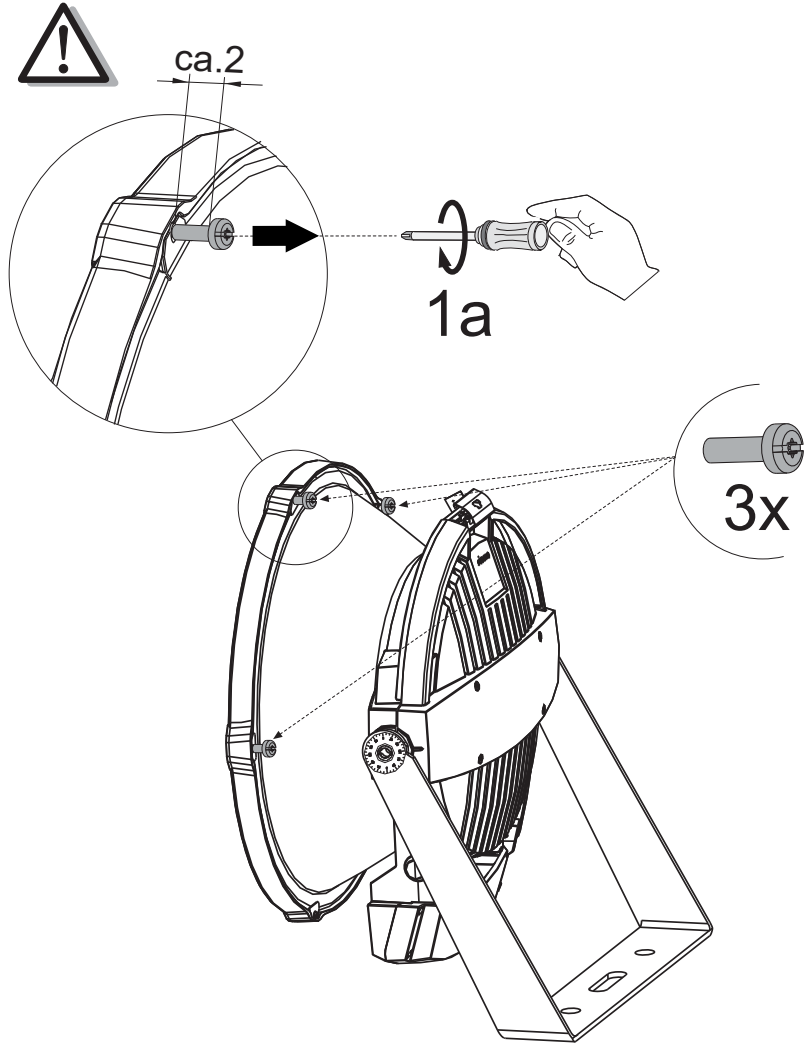

1

