

Order No.: 5XA5263ET14H000032 | GTIN (EAN): 4058352564905

Product description: CL-Eleg,ST1.2a,1470lm830,D4i,Sla/b



City-Light Elegance, mast luminaire, Module 540 Plus, primary light control with 3 zone faceted reflector, of plastic, silver coated, highly specular, structured, primary optical cover: cover, of PMMA, transparent, light distribution: ST1.2a, light emission: direct distribution, primary light characteristic: asymmetric, installation type: post-top, LED, High Power LED, rated luminous flux: 1.470lm, luminous efficacy: 104lm/W, light colour: 830, colour temperature: 3000K, control gear: ECG Smart Interface, control: overheat protection, digital communication interface, time-dependent luminous flux control, flexible luminous flux parameterisation, pre-setting: logarithmic dimming characteristic, with terminal, 6-pole, max. 2.5mm², mains connection: 230..240V, AC, 50/60Hz, start of lifetime: 14W, end of service life: 15W, reduction: 8W, luminaire housing, upper part, of aluminium, coated, Siteco® metallic grey (DB 702S), diameter: 750mm, height: 675mm, spigot size: d x l = 76 x 70mm (post-top) | with reducer (optional accessory) 60 x 70mm, post-top mast mounting element, of diecast aluminium, coated, Siteco® metallic grey (DB 702S), Module 540 Plus, traffic white (RAL 9016), Smart Interface below and above, protection rating (complete): IP65, insulation class (complete): insulation class II (safety insulation), certification: CE, ENEC, VDE, packaging unit: 1 piece



Lamps:	LED
Wt. (kg):	9.0
GTIN (EAN):	4058352564905

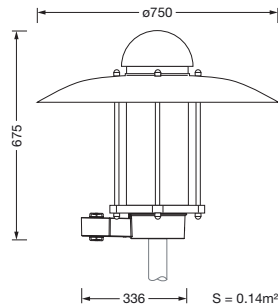

It is mandatory that the assembly instructions must be observed when planning and installing the electrical installation (to be found at www.siteco.de)

Tolerances related to thermal, electrical and photometric data according to IEC 62722

Issued 14.06.2024 - Modifications and errors subject to change - Ensure that you always use the latest version -

Order No.: 5XA5263ET14H000032 | GTIN (EAN): 4058352564905

Detailed technical description: CL-Eleg,ST1.2a,1470lm830,D4i,SlA/b



Key data

- Product type: mast luminaire
- Product name: City-Light Elegance
- Order No.: 5XA5263ET14H000032

Lighting technology | Lamps | Control gear

Component 1

Lighting technology:

- Light control: 3 zone faceted reflector of plastic, silver coated, highly specular
- Cover: cover, transparent
- Light distribution: ST1.2a
- Beam angle: wide distribution
- Symmetry: asymmetric distribution
- Light emission: direct distribution

Lamps:

- Lamps: with High Power LED, LED
- Rated luminous flux: 1470lm
- Luminous efficacy: 104lm/W
- Colour temperature: 3000K
- Colour rendering index: CRI > 80
- Light colour: 830
- SDCM (Standard Deviation of Colour Matching): MacAdam ≤ 5 SDCM (initial)
- Rated input power begin service life: 14
- Rated input power end service life: 15
- Rated input power at 50% lumin. flux: 8

Operating device:

- Control gear: ECG Smart Interface
- Control: D4i, Smart Interface below and above
- Equipment: overheat protection, digital communication interface, time-dependent luminous flux control, flexible luminous flux parameterisation, pre-setting: logarithmic dimming characteristic

Certificates, Standards

- Protection rating: IP65
- Insulation class: insulation class II (safety insulation)
- Certification, designation: CE, ENEC, VDE

Material, Colour

- luminaire housing, upper part: aluminium, coated, Siteco® metallic grey (DB 702S)
- Colour specification: Siteco® metallic grey (DB 702S)
- post-top most mounting element: diecast aluminium, coated, Siteco® metallic grey (DB 702S)
- Colour specification: Siteco® metallic grey (DB 702S)
- Colour specification: traffic white (RAL 9016)
- Cover: cover of PMMA

Mounting

- Mounting method, mounting location: post-top, on mast

Electrical connection

- Connection: terminal, 6-pole, max. 2.5mm²
- Nominal voltage: 230..240V, 50/60Hz, AC
- Surge voltage resistance: 6kV 1.2/50µs

Dimensions, Weight

- Diameter: 750mm
- Height: 675mm
- Weight: 9.0kg
- Mast spigot: spigot size: d x l = 76 x 70mm (post-top) | with reducer (optional accessory) 60 x 70mm

Light emission

- Light emission: < 3%

Service life

- Rated service life: 100000h at AT = 25°C

Order No.: 5XA5263ET14H000032 | GTIN (EAN): 4058352564905

Dimensions: CL-Eleg,ST1.2a,1470lm830,D4i,SlA/b

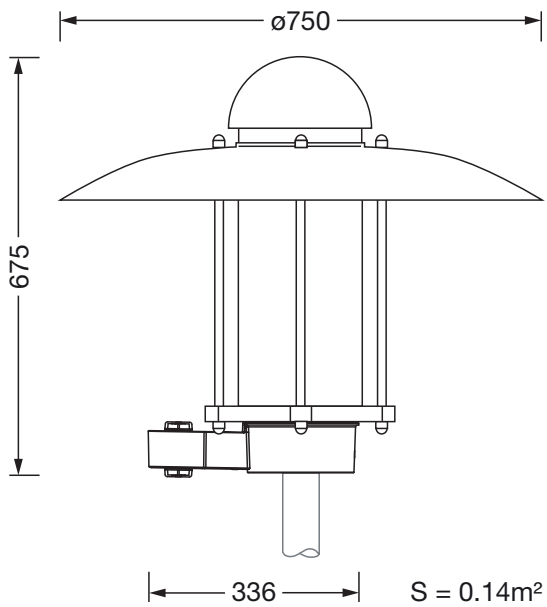

It is mandatory that the assembly instructions must be observed when planning and installing the electrical installation (to be found at www.siteco.de)

Tolerances related to thermal, electrical and photometric data according to IEC 62722

Issued 14.06.2024 - Modifications and errors subject to change - Ensure that you always use the latest version -